

COGNEX®

DataMan® 50

Quick Reference Guide

DATAMAN
ID Readers

1**Getting Started**

About DataMan 50 • For More Information • DataMan 50 Systems • DataMan 50 Accessories • Reader Layout

Page 4**2****Setting Up Your DataMan**

Setting the Focus Position • Dimensions • DataMan 50 Imager Specifications • Field of View and Reading Distances

Page 10**3****DataMan Software**

Installing DataMan Software and Connecting the Reader • Start the Setup Tool • Use the Setup Tool Menu Bar • Triggering • Training the Reader • Read Setups

Page 17**4****Connections, Optics, and Lighting**

I/O Cable • Digital Input and Output Wiring Diagrams • Illumination Strobe Output • Multi-Port Connections

Page 28**5****Compliance Information, Warnings and Notices**

DataMan 50 Specifications • Warnings and Notices • Compliance Statements

Page 38

About DataMan 50

DataMan 50 is a compact fixed-mount ID reader that among others offers the following advanced features:

- Smallest high-performance fixed mount reader
- Highest read rates for 1-D and 2-D codes
- Reliability and image feedback



The DataMan 50 reader supports RS-232 and USB interface connections in addition to discrete I/O.

The DataMan 50 reader is packaged in a rugged, IP65-rated housing.

For More Information...

This document provides basic information about how to configure and use the DataMan 50 reader. Additional information is available through the Windows **Start** menu or the Setup Tool **Help** menu after you install the DataMan software on your PC:



DataMan Communications & Programming Guide shows how to integrate your DataMan reader with your automation software and factory network.

Cognex->DataMan Software v x.x->Documentation->Communications & Programming



DataMan Reader Configuration Codes provides printable 2-D codes that you can use to configure the DataMan reader.

Cognex->DataMan Software v x.x->Documentation->English->Reader Configuration Codes



DataMan Fixed Mount Readers Reference is a complete online hardware reference for the DataMan reader.

Cognex->DataMan Software v x.x->Documentation->English->DM50->Fixed Mount Reference Manual



DataMan Questions and Answers provides context-sensitive information. You can view this help inside the Setup Tool or as a stand-alone help file.

Cognex->DataMan Software v x.x->Documentation->English->DM50->Questions and Answers



Release Notes list detailed system requirements and additional information about this DataMan software release.

Cognex->DataMan Software v x.x->Documentation->DataMan v x.y.z Release Notes

DataMan 50 Systems



Omni-directional
1-D Code Reading

IDQuick™ —
High-Speed 2-D
Reading

IDMax+™ with
HOTBARS™

DataMan 50L
(DMR-50L-00)

✓

DataMan 50S
(DMR-50S-00)

✓

✓

✓

DataMan 50 Accessories

CABLES

- ① USB Cable, 1.5 m
(DM100-USB-000)
- ② USB Cable, 3 m
(DM100-USB-030)
- ③ RS-232 Cable, 1.5 m
(DM100-RS232-000)
- ④ Extension Cable, 5 m
(DM100-EXTCBL-000)
- ⑤ RS-232/USB adapter
connector
(DM100-PATCH-000)

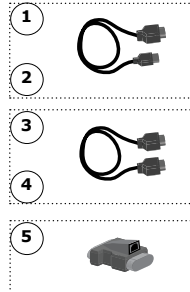

POWER SUPPLY

- ⑥ Power Supply, 6V
(DM100-PWR-000)



MOUNTING BRACKETS

- ⑦ Pivot Mounting Bracket
(DM100-PIVOTM-00)



CONTROL BOX

- ⑧ Control Box (DM-CTRLBOX-00)



DOCUMENTATION AND INSTALLER

- ⑨ DataMan 50 Quick Reference Guide
(this document) (590-7165)
- ⑩ DataMan 5.1 Thumb Drive
(DMA-USBST-510)

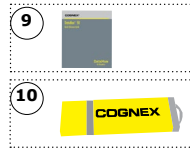

Reader Layout

The following image shows the characteristics of the DataMan 50 reader.

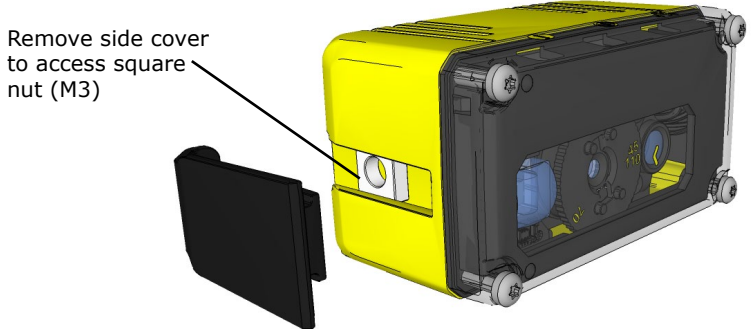
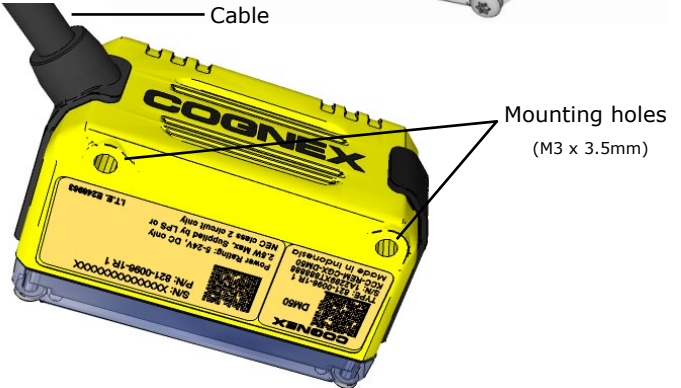
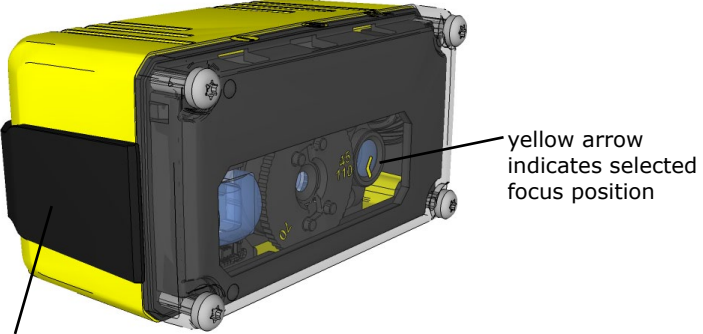
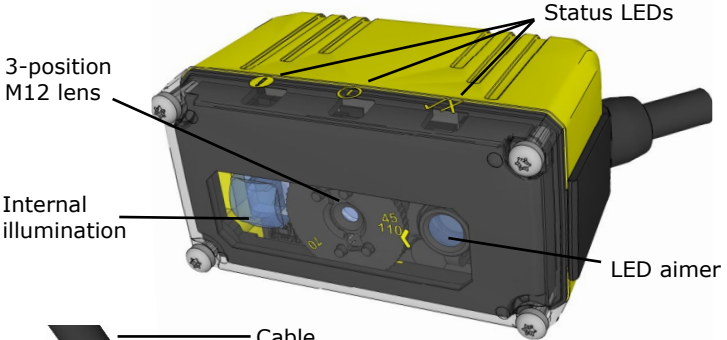

Setting the Focus Position

DataMan 50 can operate in one of three distance ranges. To set the focus position:

1 Remove screws, lens cover, and rubber part.



2 Set focus by positioning a coin into the lens cap slit and turning the coin. Do not use a coin thicker than 2 mm. If no coin is available, use the edge of the back cover.

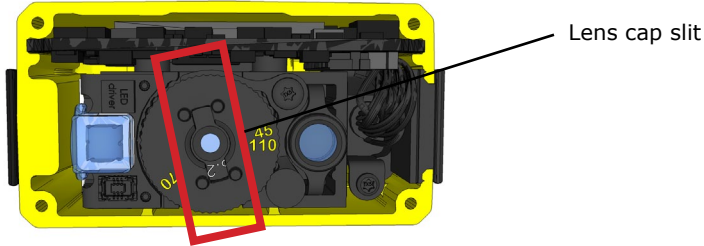

3 Make sure that the sealing and the sealing surface are clean before reassembling the lens cover.

4 Line up the holes with the icons, and attach the rubber part to the front window.

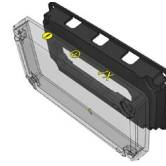

5 Attach both to housing and add screws.

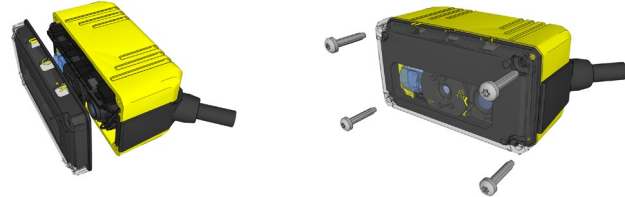

6 Tighten screws in order shown. Maximum torque for the cover screws is 8 N-cm (0.7 pound-inch). The yellow arrow on the cover indicates the selected focus position.

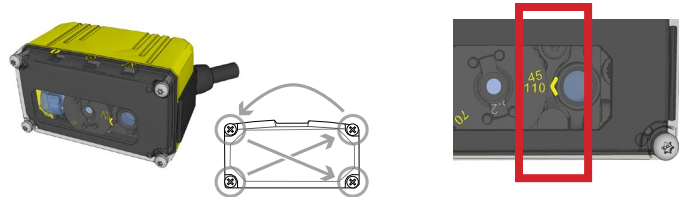

Dimensions

Observe the following DataMan 50 reader dimensions when installing your reader.

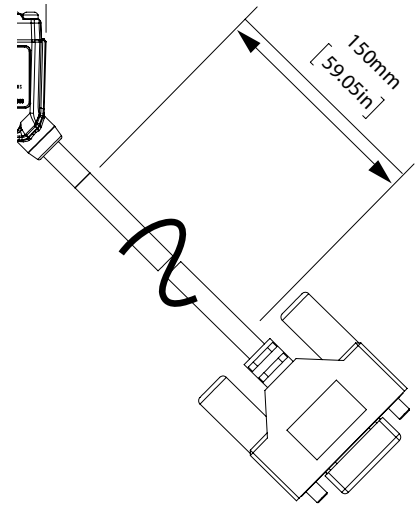
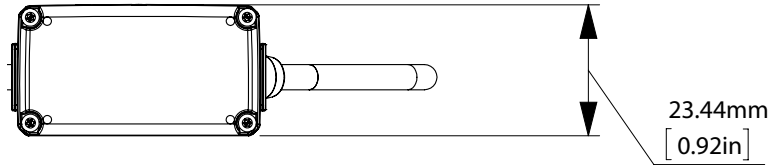
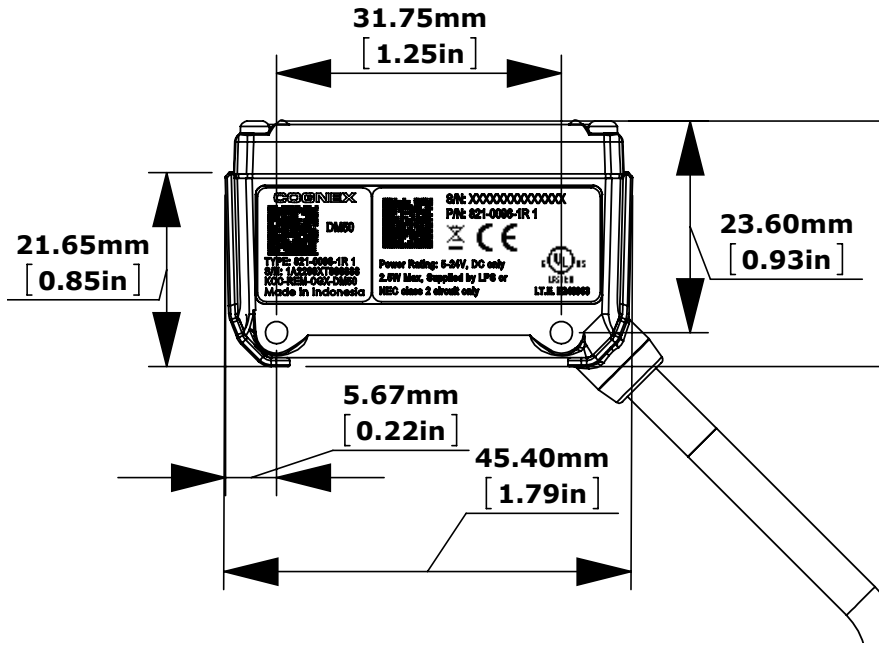

DataMan 50 Imager Specifications

Specification	DataMan 50 Imager
Image Sensor	1/3 inch CMOS
Image Sensor Properties	4.51 mm x 2.88 mm (H x V), 6.0 μm square pixels
Image Resolution (pixels)	752 x 480
Electronic Shutter Speed	33 μs to 25 ms exposure
Image Acquisition	up to 60 fps at full resolution
Lens Type	3 focal position M12 lens

Field of View

This chart shows the horizontal field of view for the DataMan 50 at a range of working distances.

The horizontal and vertical field of view is shown for working distances of 45mm, 70mm and 110mm.

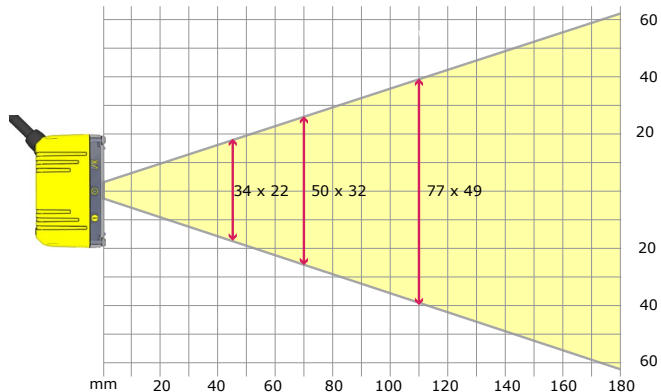

Reading Distances

This chart shows the supported range of reading distances for four code sizes (6, 8, 10, and 12 mil) at each of the three focus positions (45 mm, 70 mm, and 110 mm).

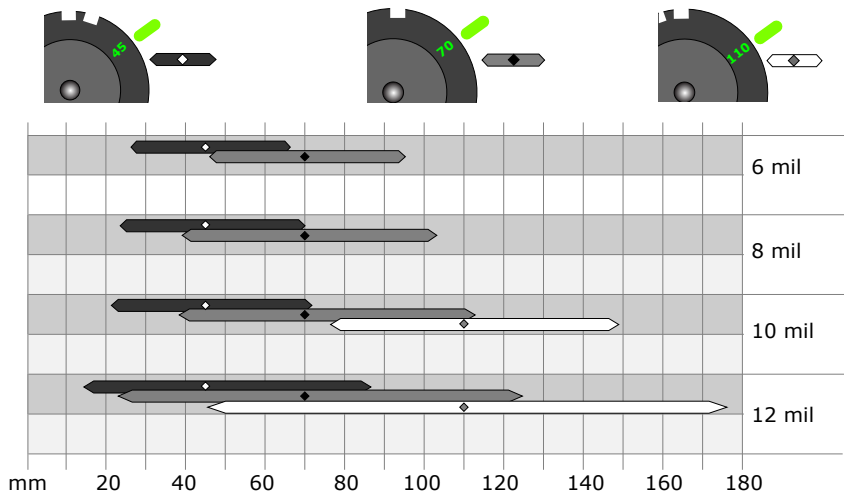

Installing DataMan Software and Connecting the Reader

INSTALL DATAMAN SOFTWARE AND CONNECT

1. Check the DataMan Release Notes for a full list of system requirements.
2. Insert CD-ROM and follow the on-screen prompts until you successfully completed the DataMan Software installation process.
3. Connect the DataMan 50 reader to your PC.
4. Launch the Setup Tool and click **Refresh**.
Detected readers will appear under **COM ports**.
5. Select a reader from the list and click **Connect**.

CONNECT YOUR READER

1. Connect the cable on the back of the device to either an USB adapter cable with power tap or to an RS-232 adapter cable with power tab.
2. Connect either the USB or the RS-232 connector to your PC.
3. Connect a 6V power supply.

Start the Setup Tool

Connect the reader to the Setup Tool to configure it with the type of symbologies it will decode as well as other parameters, such as the type of trigger it will use and the format of the results it will generate.

Alternatively, configure your reader by scanning the appropriate reader configuration code from the *Reader Configuration Codes* document, available through the Windows Start menu or the Setup Tool Help menu.

Quick Setup

All main controls and visual feedback in a single view, for easiest setup and configuration

Connect to Reader

Establish a connection to the reader

Results Display

View results

Light and Imager Settings

Choose a trigger type and other acquisition parameters

System Settings

Configure visual and audio feedback, trigger and output actions

Table View

See all the selectable values in the Setup Tool in one table

The screenshot shows the DataMan Setup Tool interface. Callouts point to the following features:

- Trigger button**: A button labeled 'Trigger' in the Quick Setup window.
- IN1 button**: A button labeled 'IN1' in the Quick Setup window.
- Latest image**: A QR code image displayed in the Quick Setup window.
- Code information**: Text above the QR code: 'http://kaywa.me/Dx89H Direct Mark QR, 11.46 PPM'.
- Region of interest**: A green box highlighting the QR code.
- Context based help**: A 'Q+A Help' window on the right side of the interface.
- Read history**: A table at the bottom of the interface showing a list of decoded data.
- Train status**: A status indicator at the bottom right showing 'Untrained'.
- Connection status**: A status indicator at the bottom right showing 'Connected'.

Data	Time Stamp
http://kaywa.me/Dx89H	15:09:56.810
http://kaywa.me/Dx89H	15:09:56.282
http://kaywa.me/Dx89H	15:09:55.636
http://kaywa.me/Dx89H	15:09:55.086

Use the Setup Tool Menu Bar

The In1 button on the toolbar creates a virtual rising edge signal on Input 1. Use the In1 button to activate various actions such as training a code, optimizing brightness or setting a match string without a physical input 1 channel.

Each reader can store its current set of runtime parameters to a configuration (.cfg) file, which contains information such as the enabled symbologies and how any output data should be formatted.

The same configuration file can be loaded onto multiple readers, as the file does not contain identification information such as the device name of the reader used to create it.

A reader can also generate a Cognex device configuration (.cdc) file, which stores the set of runtime parameters plus any identification data, such as the name of the device. Cognex recommends generating a device configuration file for each reader to allow you to restore a reader to its operating state with minimal effort.

Use the **File** menu of the Setup Tool to manage .cfg and .cdc files, export parameters, or to load, save, or train uploaded images.

File Menu	
Open Configuration	Open a saved .cfg configuration file.
Save Configuration	Create a .cfg configuration file of current runtime parameters.
Restore Device	Load a saved device configuration .cdc file, with runtime parameters plus device-specific information for a particular DataMan reader.
Backup Device	Create a device configuration .cdc file for a specific reader.
Export Parameters	Save (all or only the non-default) parameters of your device in a text file.
Load Image	Load an 8-bit uncompressed grey-scale .bmp or .jpg image for analysis.
Save Image	Save the latest acquired image with the .jpg or .bmp file format.
Save Burst Images	Save the latest batch of burst images.
Train Image	Upload an image to be used for training.

Use the Setup Tool Menu Bar (Continued)

Use the **Edit** menu for standard Cut, Copy and Paste operations.

Use the **View** menu to view reader information (serial number, firmware version, and so on) and to enable and disable various elements of the Setup Tool, and the **Tasks** menu to switch between various Setup Tool options.

Use the **System** menu to manage the current settings on the reader and to upgrade the features it currently supports:

System Menu

Save Settings	Save the current parameters to non-volatile memory, which allows the reader to restore these settings each time you reboot it.
Reset Configuration	Reset all configuration parameters in RAM (volatile memory) to the default settings.
Update Firmware	Update the reader software.
Upload Feature Key	Unlock additional features available in the reader software if you have the right key.
Show Device Log	Error and exception conditions, such as missed triggers and trigger overruns are logged.
Delete Device Log	Clear your device log.

Use the **Help** menu to display Setup Tool version information.

DataMan 50 Triggering

DataMan 50 readers support the following trigger modes:

- **Self:** At an interval you configure, the reader automatically detects and decodes codes in its field of view. If you set a higher re-read delay than the trigger interval, there is a code output only once until the code is out of the field of view for the duration of the re-read delay.
- **Single (external trigger):** Acquires a single image and attempts to decode any symbol it contains, or more than one symbol in cases where multicode is enabled. The reader relies on an external trigger source.
- **Presentation:** Scans, decodes and reports a single code in the field of view. The reader relies on an internal timing mechanism to acquire images.
- **Manual:** Begins acquiring images when you send an external trigger, and continues acquiring images until a symbol is found and decoded or you stop the external triggering.
- **Burst:** Performs multiple image acquisitions based on an external trigger and decodes any symbol appearing in a single image or within a sequence of images, or multiple symbols in a single image or within a sequence of images when multicode is enabled. You can control the number of images within each burst and the interval between image acquisitions.
- **Continuous:** Begins acquiring images based on a single external trigger and continues to acquire and decode images until a symbol is found and decoded, or until multiple images containing as many codes as specified in multicode mode are located, or until the trigger is released. You can configure your reader to acquire images based on the start and stop signal from separate digital IO pulses.

External Triggers

If you are using external triggering you can use any of these methods to trigger your DataMan 50 series reader:

- Send a pulse on the I/O cable:
 - Input 0 (white)
 - Input 1 (white/black)
- Send a serial trigger command over the RS-232 connection.
- Press <CTRL>-T on the keyboard while the Setup Tool has the input focus.
- Click the Trigger button in the Setup Tool:

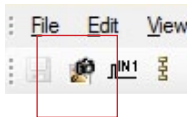

Training the Reader

Training your reader with the expected symbology can make the time required to decode successive symbols more consistent. In addition, training may help increase decode yield.

To train your reader, place a code in front of the reader and do one of the following:

- Click and hold the trigger button in the Setup Tool for a minimum of 3 seconds.

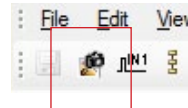

- Click **Train Code** in the Results Display pane.

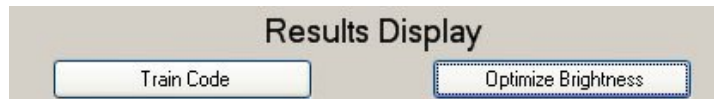

- Upload the code through **File** menu → **Train Image**.

You can use training in Single, Burst, Continuous or Self trigger modes.

NOTE that only a single symbol of each symbology kind can be trained.

Training the Reader (Continued)

Incremental Training for Multiple Symbologies

If you want to train the reader to recognize multiple symbologies, you can present a single image showing all the desired symbologies and perform the training procedure previously described.

If you cannot present a single image showing all the necessary symbologies, you can enable incremental training on the **Training** tab of the **Symbology Settings** pane:

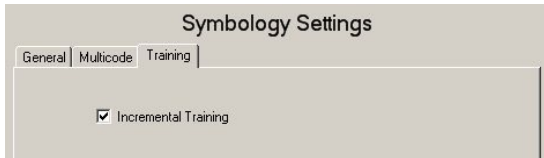

With incremental training enabled, you can train the reader using multiple images showing the symbologies you expect to decode. The reader will train each new symbology while retaining the existing trained symbologies.

Read Setups

It is possible to configure a variety of acquisition parameters for your DataMan 50 reader on a unified Read Setups pane.

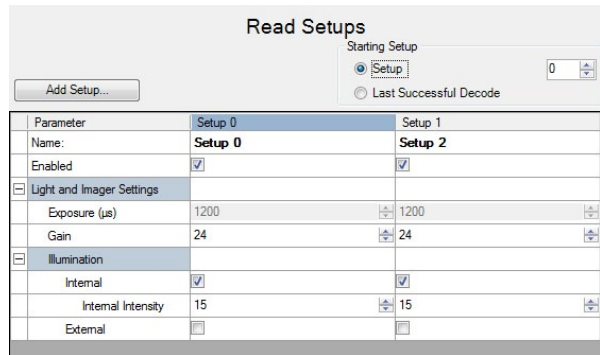

Your reader can be configured for up to 16 different settings. In *Single trigger mode*, you can enable multiple (or all) setups, and the DataMan 50 reader goes through all of the configured imager combinations until there is a decoded image or there are no images left (that is, a no read image).

You can change the parameters for the setups either on its dedicated pane, or in the **Read Setup** pane's appropriate table cell. Whatever you change on either pane is mirrored on the other.

The read setup process starts with either a specific setup, or the Last Successful Decode (as you choose).

The currently selected setup also gets represented on other panes.

I/O Cable

The I/O cable provides access to trigger and high-speed outputs. Unused wires can be clipped short or tied back using a tie made of non-conductive material.

For RS-232, use the Power Supply return path for ground.

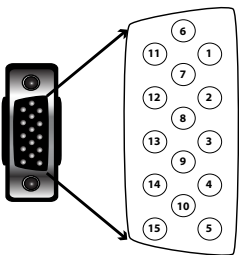

PIN	Color	Signal
1	Brown	Reserved
2	Green	TxD
3	Green/Black	RxD
4	Red & Red/Black	GND
5	Brown/White	DC+ (system power, 5-24 VDC)
6	Blue	RTS
7	Blue/White	Output-0
8	White	Input-0
9	White/Black	Input-1
10	Light Blue	CTS
11	Light Blue/Black	Output-1
12	Light Blue/Yellow	Output-Common
13	Light Blue/Green	Output-Strobe
14	Yellow	Reserved
15	Yellow/Black	Reserved

Digital Input Lines

Inputs are not galvanic isolated but need to be referenced to ground.

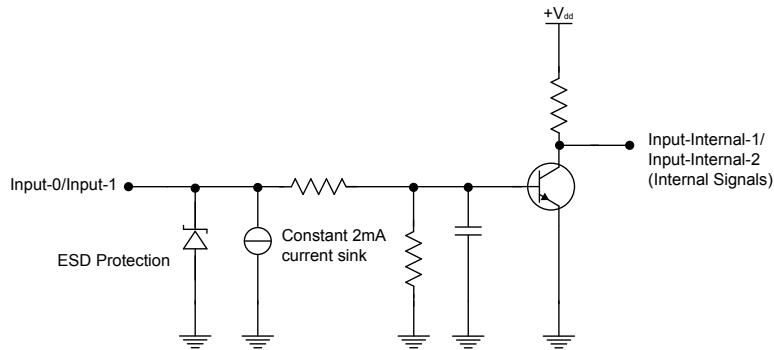

Digital Output Lines

The digital outputs can be used as either NPN (pull-down) or PNP (pull-up) lines. For NPN lines, the external load should be connected between the output and the positive supply voltage (<26V). The outputs pull down to less than 3V when ON, which causes current to flow through the load. When the outputs are OFF, no current flows through the load. Outputs are not galvanic isolated but need to be referenced to ground.

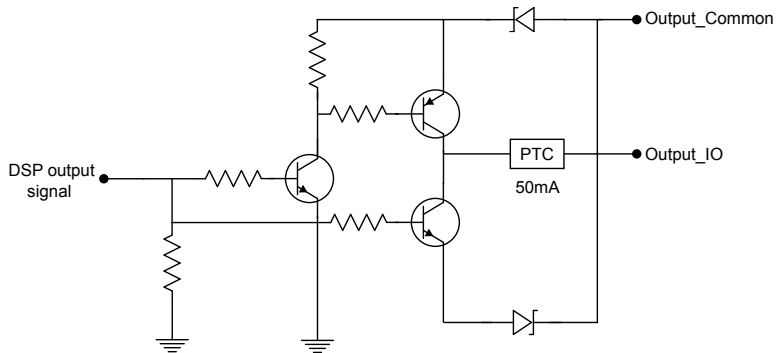

NPN (pull down) output type characteristics are the following:

Applied voltage	26 VDC or less
Residual voltage	0.85V or less
Maximum sink current	25mA
Short-circuit current	100mA or less
Short-circuit protection	multifuse - 50mA

PNP (pull up) output type characteristics are the following:

Output voltage range	26V or less
Residual voltage	0.8V or less
Maximum source current	25mA
Short-circuit current	50mA or less
Short-circuit protection	multifuse - 50mA

Illumination Strobe Output

The strobe output is provided by a diode that is added to the push-pull circuit, with series to the pull-up transistor. This diode blocks the higher voltage when the output is pulled up when used as open-collector type driving, but enables the driving of high level in TTL mode.

TTL output type characteristics are the following:

High level	4.0-5.0V
Low level	0-0.4V
Output current	25mA
Short-circuit current	125mA
Short-circuit protection	multifuse - 50mA

Open-collector output type characteristics are the following:

Output voltage range	0-26V
Low level	0-0.4V
Output current	25mA max
Short-circuit current	125mA
Short-circuit protection	multifuse - 50mA

The following figure shows the wiring diagram of the illumination strobe output.

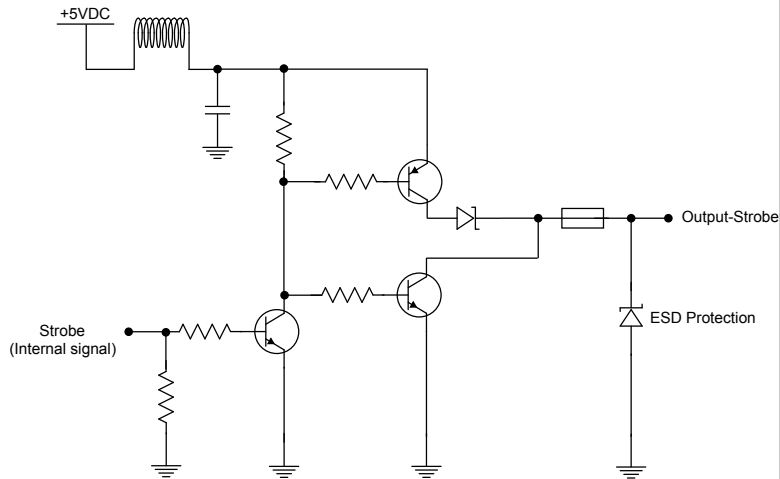

Multi-Port Connections

You can connect multiple DataMan 50 readers to a single PC (or other device equipped with a serial port) using a multi-port connection.

A multi-port connection creates a daisy-chain of readers. Each reader receives serial data from the previous reader and transmits it to the next reader. When a reader transmits data, it is passed through each of the readers in the chain between it and the PC.

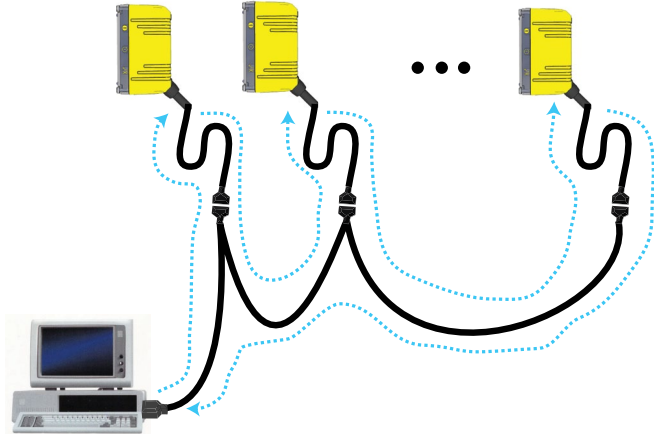

Because of the large number of possible configurations, Cognex does not supply cabling for multi-port DataMan 50 connections. Instead, you must construct your own cable that meets the requirements of your system configuration.

The cable must provide a DB-9 connector for each DataMan 50 serial cable and a DB-9 connector for the PC serial port. Each DB-9 connector must provide Tx

Data, Rx Data, and ground. The Tx Data and Rx Data pins on adjacent connectors must be connected to provide the multi-port connection.

The following diagram shows how to create a multi-port cable for a 3-reader system:

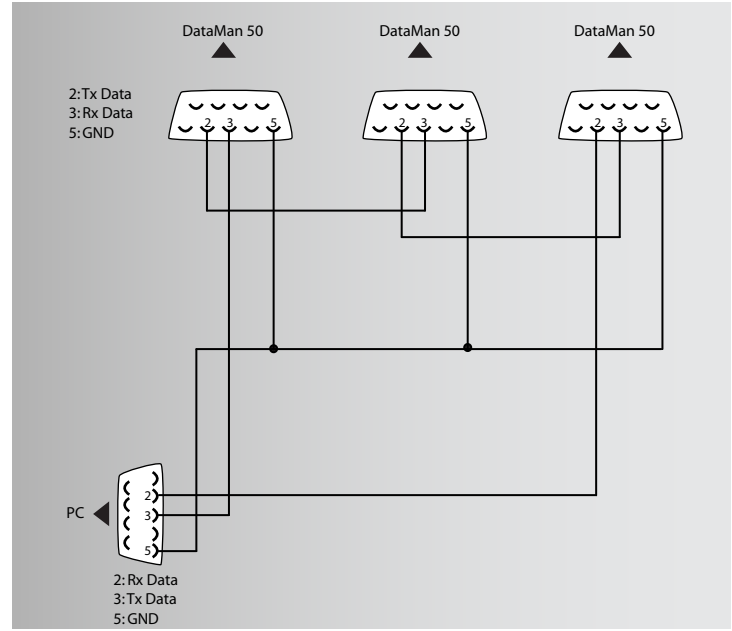

Configuring for Multi-Port Operation

You must connect the Setup Tool to each DataMan 50 in turn and enable multi-port operation. Click the **Communication Settings** task and check the **Enable Multi-Port (RS-232 Sharing)** check box.

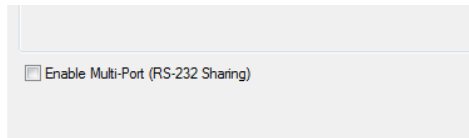

There is no guaranteed delivery order when multiple readers transmit data using a multi-port connection; read results may arrive at the PC in any order. You can configure each DataMan 50 reader in a multi-port connection to add identifying data to each read result. Your PC application can then determine which reader produced a specific read result.

To do this, click on the **Data Formatting** task, click the appropriate **Standard** box (for each symbology that you are using), go to the **Standard Formatting** pane, and enter text in the **Leading Text** field. (You can also add trailing text by entering text in the **Terminating Text** field.)

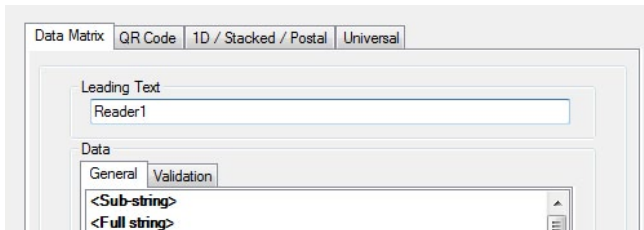

Multi-Port Usage Notes

You can obtain the best results when using multi-port connections by keeping the following usage guidelines in mind as you design your system:

- The maximum cable length between any two DataMan readers or between the PC and any DataMan reader should be no greater than 15 meters.
- There is no fixed limit to the number of DataMan readers that you can connect to a single PC. Each reader introduces a delay of about 100 msec when it retransmits received serial data. If you have 5 readers, this means that there will be a 400 msec delay between the time the first reader in the chain transmits data and the PC receives it.
- Each DataMan reader must receive a hardware trigger signal on its Input 0 line. You can wire the input ports to a common trigger signal or you can provide individual triggers for each reader.
- If *any* reader in the multi-port chain loses power or becomes disconnected, then no data from any other reader will be transmitted.
- If a DataMan is transmitting its own read result, it will buffer any data received from another reader until it has finished its own data transmission. If a DataMan reader is transmitting another reader's data, it will buffer its own data if it receives a trigger signal while it is processing the other reader's data.
- If you use a single power supply for multiple readers, make sure that the power supply can provide enough power for all of the readers.
- You cannot connect a reader to the Setup Tool over RS-232 once multiport is enabled. You must first scan the Disable Multi-Port code from the Reader Configuration Codes, available from the **Start** menu.

DataMan 50 Specifications

Weight	76 g (including cable)		
Operating Temperature	0°C — 40°C (32°F — 104°F)		
Storage Temperature	-10°C — 60°C (-14°F — 140°F)		
Maximum Humidity	95% (non-condensing)		
Environmental	IP65		
Vibration	EN61373 including IEC 60068-2-6, 60068-2-64 6.4, and 60068-2-27		
Codes	Data Matrix™ (IDMax: ECC 0, 50, 80, 100, 140, and 200; IDQuick: ECC200) Vericode (optional) QR Code and microQR Code, MaxiCode UPC/EAN/JAN Codabar, Interleaved 2 of 5, Code 39, Code 128, and Code 93, Pharma, Postal, RSS/CS, PDF 417, MicroPDF 417		
Discrete I/O operating limits	Output 0,1	I_{MAX} @ 24 VDC	25 mA
		V_{MAX}	26 V
	Output 2	Source V_{TYP}	4 V
	Sink V_{IH}	4 - V_{PSU}	V
	V_{IL}	0 — 2	V
	Input 0 (Trigger)	V_{IH}	4 — 26 V
	Input 1	V_{IL}	0 — 2 V
		I_{TYP}	3 mA
Power Supply Requirements	V_{PSU} 4,5 — 26 VDC 2.5 W maximum LPS or NEC class 2 power supply		

Warnings and Notices



NOTE: For product support, contact <http://support.cognex.com>



CAUTION: IP protection is ensured only when all connectors are attached to cables or shielded by a sealing cap.



CAUTION: LED RADIATION - DO NOT VIEW DIRECTLY WITH OPTICAL INSTRUMENTS - CLASS 1M LED PRODUCT

Compliance Statements

DataMan 50 readers meet or exceed the requirements of all applicable standards organizations for safe operation. However, as with any electrical equipment, the best way to ensure safe operation is to operate them according to the agency guidelines that follow. Please read these guidelines carefully before using your device.

Regulator	Specification
USA	FCC Part 15, Subpart B, Class A
Canada	ICES-003, Class A
European Community	EN55022:2006 +A1:2007, Class A EN55024:1998 +A1:2001 +A2:2003
Australia	C-TICK, AS/NZS CISPR 22 / EN 55022 for Class A Equipment
Japan	J55022, Class A

FCC Class A Compliance Statement



This equipment has been tested and found to comply with the limits for a Class A digital device, pursuant to Part 15 of the FCC rules. These limits are designed to provide reasonable protection against harmful interference when the equipment is operated in a commercial environment. This equipment generates, uses, and can radiate radio frequency energy and, if not installed and used in accordance with the instructions, may cause harmful interference to radio communications. Operation of this

equipment in a residential area is likely to cause harmful interference, in which case the user will be required to correct the interference at personal expense.

Canadian Compliance

This Class A digital apparatus complies with Canadian ICES-003.

Cet appareil numérique de la classe A est conforme à la norme NMB-003 du Canada.

C-Tick Statement



Conforms to AS/NZS CISPR 22/ EN 55022 for Class A Equipment.

European Compliance



The CE mark on the product indicates that the system has been tested to and conforms to the provisions noted within the 2004/108/EEC Electromagnetic Compatibility Directive.

For further information please contact:

Cognex Corporation
One Vision Drive
Natick, MA 01760
USA

Cognex Corporation shall not be liable for use of our product with equipment (i.e., power supplies, personal

computers, etc.) that is not CE marked and does not comply with the Low Voltage Directive.

For European Community Users

Cognex complies with Directive 2002/96/EC OF THE EUROPEAN PARLIAMENT AND OF THE COUNCIL of 27 January 2003 on waste electrical and electronic equipment (WEEE).

This product has required the extraction and use of natural resources for its production. It may contain hazardous substances that could impact health and the environment, if not properly disposed.

In order to avoid the dissemination of those substances in our environment and to diminish the pressure on the natural resources, we encourage you to use the appropriate take-back systems for product disposal. Those systems will reuse or recycle most of the materials of the product you are disposing in a sound way.



The crossed out wheeled bin symbol informs you that the product should not be disposed of along with municipal waste and invites you to use the appropriate separate take-back systems for product disposal.

If you need more information on the collection, reuse, and recycling systems, please contact your

local or regional waste administration.

You may also contact your supplier for more information on the environmental performance of this product.

Reader Programming Codes



Reset Scanner to
Factory Defaults



Reboot Scanner

Copyright © 2013 Cognex Corporation All Rights Reserved. This document may not be copied in whole or in part, nor transferred to any other media or language, without the written permission of Cognex Corporation. The hardware and portions of the software described in this document may be covered by one or more of the U.S. patents listed on the Cognex web site <http://www.cognex.com/patents.asp>. Other U.S. and foreign patents are pending. Cognex, the Cognex logo, and DataMan are trademarks, or registered trademarks, of Cognex Corporation.



590-7165

P/N 590-7165